

1

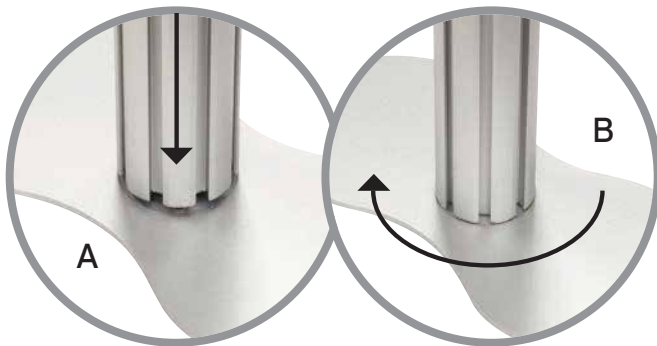

Place base plate on the floor, position lower post centrally over male fitting of base plate (A), and rotate until assembly drops into position, continue rotating clockwise through 90° to secure (B).



2



Affix upper post to lower post by positioning female end centrally over male fitting (C), and rotate until assembly drops into position, continue rotating clockwise through 90° to secure (D).

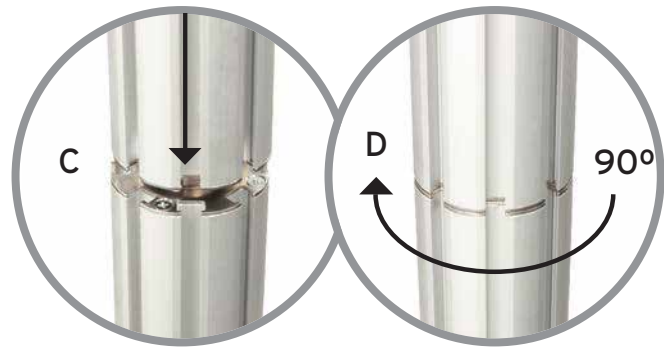

3

Repeat for remaining base and posts to complete assembly of uprights.

4.1

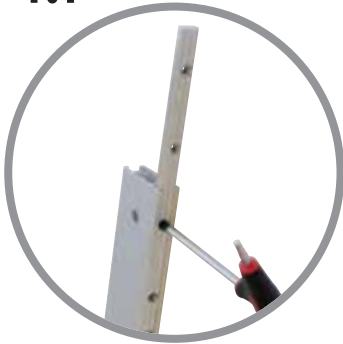

4.2.1



4.2.2



4.2.3

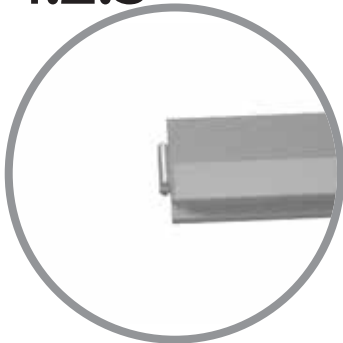

To join the horizontal (H, H1, and H2) and vertical (V and V1) frame profiles:

- 4.1) Loosen grub screws and slide connector bars halfway out of the channel.
- 4.2) Join profiles ensuring graphic fixing strips are aligned and the expanding clamps are at either end of the assembled profiles.

5.2i



5.2ii



5.3



5.2i) Centre vertical 'V1' differs due to the presence of twin graphic fixing strips.

5.2ii) Bottom horizontal 'H2' differs with the introduction of the adjustable thumb screw foot in the centre.

5.3) Tighten grub screws to make secure.

6.1



6.2



6.3



Connect two vertical (V) 1531mm assembly rails at 90° to each end of the 1500mm horizontal rail (H2) ensuring that the graphic fixing strip is outermost and the verticals are flush with the end of the 1500mm rail. Bottom horizontal 1500mm rail (H2) should have an adjustable thumbscrew foot in the middle of a 260mm connector bar. Connect middle vertical rail (V1- with twin graphic fixing strips) to centre of the assembled horizontal (H2) using the expanding clamp. Tighten 3 bottom grub screws in expanding clamps on verticals to secure to horizontal.



7.1



7.2



7.3



Connect second horizontal 1500mm rail assembly (H), using the expanding clamps, to top of assembled verticals (V, V1 and V) ensuring that the graphic fixing strip is at the bottom. Tighten grub screws on vertical rails to secure. This completes the bottom section of the framework.



8.1



8.2

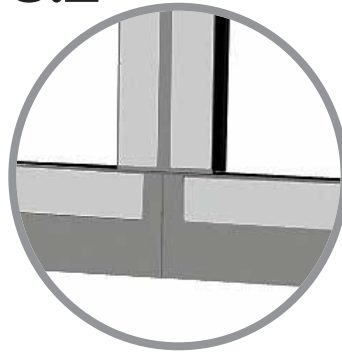

8.3



For the top section of the framework, connect the two 220mm profiles, with expanding clamps at both ends and the single fixing strip, at 90° flush to each end of the third 1500mm horizontal rail (H). Ensure that the graphic fixing strip on the verticals are outermost and the graphic fixing strip on the horizontal 1500mm rail is at the top. Affix 220mm vertical profile, with expanding clamps at both ends and twin fixing strip, to middle of 1500mm horizontal. Tighten lower grub screws adjacent to horizontal rail assembly to secure 220mm verticals.



9.1



9.2



9.3



Slot final top horizontal 1500mm rail assembly (H1) to the 220mm verticals, ensuring that the graphic fixing strip is at the top. Tighten grub screws on verticals to secure framework. This completes the top section of the framework.



10.1



10.2



Slot the bottom section framework into the channel of the assembled post at 90° to the base plate. Ensure framework is equidistant from the base plate, adjustable foot rests on the ground, and graphic fixing strip is adjacent to the floor. Tighten both grub screws in the horizontals (H2 and H) to secure.

11.1



11.2



Slot open end of framework into other assembled post, at 90° to the base plate. Ensure bottom section is equidistant from the floor at both ends and the adjustable foot rests on the floor. Tighten remaining grub screws in horizontals (H2 and H) to secure bottom section framework to both post assemblies.



12.1



12.2



Affix the top section framework into the same channel as the bottom section ensuring graphic fixing strips are all on the same side of the system. Leave a gap of 60mm in between bottom and top framework assemblies and tighten all grub screws in horizontals (H and H1) to secure to post.



13

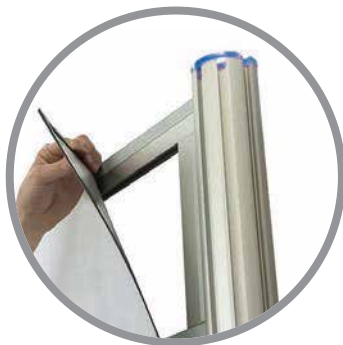

Starting from the top left-hand side of the system, unroll the first graphic panel and align the magnetic tape with steel fixing strips of the framework. Work across the frame, taking care not to crease the panel. Repeat for remaining graphic panel.

14.1



14.2



14.3



Remove two inner screws from LED/LCD mounting bracket and loosen two outer screws so there is sufficient gap between connector bars to slide onto framework profile.

15.1

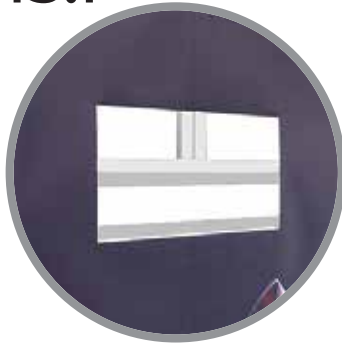

15.2

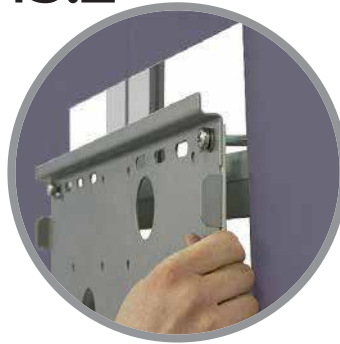

15.3



Position and lower outer screws centrally over upper horizontal rail in aperture.



16.1



16.2



16.3



Raise screen mount so bottom holes are above the lower horizontal rail in aperture. Re-insert 2 screws through lower/inner mount holes (4 openings from either end of the screen mount) and clearance holes in 2 off 260mm connector bars adjacent to mount.



17.1



17.2



Align other 2 off 260mm connector bars, located behind horizontal rails, and screw into threaded holes. Ensure bottom screws rest on lower horizontal rail, mount is in centre of aperture, and tighten all 4 screws to secure assembly.



18



With the elongated holes on the mounting arms uppermost, align arms centrally with 4 off fixing points on rear of screen equidistant from the top. Insert 4 off screws with suitable washers and tighten.

19



Position screen centrally above bracket and lower until top of both mounting arms hook over mount.



20.1



20.2



Slide locking bar between the mounting arms and the plasma mounting bracket if desired. For extra security, there is a facility to add a padlock to the locking bar.

21

To complete Centro Multimedia Kit 2 display, please affix podium table to the front of one of the posts.

